

On the State-Space Representation of Local Affine Models in Takagi–Sugeno–Kang Fuzzy Systems

Zur Zustandsdarstellung von Takagi–Sugeno–Kang-Fuzzy-Systemen mit Lokal Affinen Modellen

Andreas Kroll

Considering the constant terms in the local models of dynamic Takagi–Sugeno–Kang fuzzy models can provide for improved prediction quality. However, the constant terms have typically not been treated analytically in analysis and controller design. In this paper, minimal state-space representations are derived from local affine input/output models for usage in TSK fuzzy models. Transformation algorithms for structure, parameters and initial values are proposed.

Die Berücksichtigung der konstanten Terme in den lokalen Modellen dynamischer Takagi–Sugeno–Kang-Fuzzy-Modelle ermöglicht eine erhöhte Prädiktionsqualität. Jedoch werden diese konstanten Terme typischerweise bei Systemanalyse und Reglerentwurf nicht analytisch berücksichtigt. Im Beitrag werden lokale Modelle in minimaler Zustandsdarstellung aus affinen Modellen in Ein-/Ausgangsform für die Verwendung in TSK-Fuzzy-Modellen hergeleitet. Umrechnungsvorschriften für Modellstruktur und -parameter sowie für Anfangswerte werden angegeben.

Keywords: Takagi–Sugeno–Kang fuzzy systems, affine models

Schlagwörter: Takagi–Sugeno–Kang-Fuzzy-Systeme, affine Modelle

1 Introduction

Regime-wise modeling is an approach to decompose complex nonlinear global models into a set of easier-to-handle local models. Takagi–Sugeno–Kang (TSK) fuzzy systems follow this concept. Published work on TSK-systems typically focuses on either fuzzy modeling or on fuzzy control. Algorithms on system identification typically provide for dynamic TSK fuzzy models with affine conclusions of the local models. This means, each conclusion features a constant term besides delayed input and output terms. However, contributions addressing TSK fuzzy model-based controller design typically assume models with linear conclusions to permit applying methods from linear system theory.

This contribution discusses how *affine* local models in input/output form of dynamic TSK fuzzy models can be transferred into state-space representation (in controller canonical form). The aim is to better understand the impact of the constant terms, when transferring analytical

design concepts from linear system theory such as local pole placement. Discrete-time systems are considered.

The paper is organized as following: The next section overviews related work. Section 3 recalls dynamical TSK fuzzy models. Transformation of TSK model in input/output (I/O) form into state-space form is discussed in Section 4 and illustrated with an example in Section 5. Section 6 and 7 summarizes the paper. For enhanced readability proofs have been moved to the appendix.

2 Related Work

Several concepts of regime-based modeling have been proposed: “Takagi–Sugeno”/“Takagi–Sugeno–Kang (TSK)” fuzzy models [37] typically compose several affine or linear local dynamic models to form a non-linear global model. The smooth transition between the local models is achieved by weighting each local model. The membership functions, which are used for the weighting, express the validity of the

local models for a given input. Such a model can also be written as a “linear/affine time varying system” [49].

“Continuous piecewise linear (CPWL) models” are models, where the global model is composed of a set of dynamic local affine models. In contrast to TSK models, just one model is valid at a time, i.e. the models are switched crisply, e.g. [15; 24]. A continuous transition between two neighboring local models (“polytypes”) is enforced by continuity constraints, which are part of the system description. TSK and CPWL models typically follow the concept of covering the entire subspace of considered system operations. They use off-line methods for identification. “Multi-model”/“multi-controller” approaches use dynamic linear/affine local models or controllers, which are switched in a crisp manner. It is assumed that models are only available for some of the operating points. New models are added during operation as required [28; 30].

Radial basis function (RBF) and hyper basis function (HBF) networks [31] can be interpreted to follow the concept of a soft composition of *static* local models.

This contribution focuses on TSK fuzzy systems. TSK fuzzy models are particularly interesting due to their good prediction quality. Their semi-linguistic structure makes it easier to transfer methods from linear system theory. An example is the “parallel distributed compensator”, e.g. [47]. Moreover, their affinity to Linear Matrix Inequalities (LMIs), an area with significant recent progress [5], makes them attractive.

TSK fuzzy models can be derived from theoretical models, e.g. by regime-wise approximation of a physical model [12; 19; 41], or by identification [2; 3; 9; 21; 29; 36]. Reference [13] provides for a more detailed motivation and a literature survey. A state-space representation is advantageous for analysis and controller design. Several contributions use fuzzy models with local models in state-space representation for fuzzy observer and controller design [7; 27], or just for controller design [20; 22; 41; 50]. However, identification algorithms typically yield models in input/output and not in state-space form. The affine nature of the model is commonly considered in context of investigating approximation capabilities [32] or in case of non-state-space TSK fuzzy control applications. Examples for the latter are: TSK PID controllers [8], TSK time-optimal controllers [10], and controller derivation by TSK fuzzy model identification [37]. However, until recently “homogeneous” or “linear” TSK fuzzy systems [6; 20; 22; 23; 27; 38; 39; 41; 43; 44; 47–50] were used in context of state-space control and stability analysis due to the easier handling [17; 46]. This means that each conclusion consists of a linear state-space model. Remarks on required research on an affine extension were given in some works [14; 19]. Recently, the interest in affine TSK fuzzy state-space models rose: Augmentation of the output equations by local offset terms was proposed. This leaves the system equations linear and permits regime-wise linear design methods [7]. Adding local offset terms to the system equations was proposed in conjunction with LMI-based analysis and design

methods [4; 17]. A trajectory generator can be used to compensate the offset terms, which appear in output and system equations [12]. An analytical local offset compensation in tandem with pole placement is proposed in [45]. In [25] the affine model equations are differentiated in order to eliminate the constant, which is referred to as “velocity-based” model form. Both, continuous-time [4; 7; 12; 45] and discrete-time [17] cases were discussed.

3 Dynamic Takagi–Sugeno–Kang Fuzzy Systems

Dynamic TSK fuzzy systems are composed of a set of *c* semi-linguistic rules, like the following:

$$\text{IF } (Z_1 \text{ IS } Z_{1,\text{ref}}) \text{ AND } \dots \text{ AND } (Z_g \text{ IS } Z_{g,\text{ref}}) \text{ THEN } f_i .$$

The premise can be described by a set of scalar fuzzy sets with the affiliated set of scalar membership functions. Alternatively, multi-dimensional fuzzy sets/membership functions can be used. Then a premise can be written as: IF (Z IS $Z_{i,\text{ref}}$) [3]. A membership function produces a value $\mu_i(k) \in [0, 1]$ at each discrete-time instant *k*, which represents the degree of fulfillment of the *i*-th rule. A conclusion contains a dynamic local model f_i . Typically, each conclusion has the same structure. In case of a SISO model, an I/O type conclusion commonly looks like the following:

$$Y_i(k) = \theta_i [Y(k-1), \dots, Y(k-n-1), U(k-1), \dots, U(k-m-1)]^T + \xi_i , \tag{1}$$

θ_i is the vector of the conclusion parameters. The predictions of the *c* local models are superposed fuzzily in order to form the global nonlinear dynamic TSK model: Each local prediction is weighted with the degree of fulfillment of its rule and then summed up to form the global prediction (Fig. 1):

$$Y(k) = \frac{\sum_{i=1}^c \mu_i(k-1) Y_i(k)}{\sum_{i=1}^c \mu_i(k-1)} = \sum_{i=1}^c \phi_i(k-1) Y_i(k) . \tag{2}$$

ϕ_i is referred to as “fuzzy basis function”. $\phi_i \equiv \mu_i$ holds for orthogonal membership functions. TSK models with state-space type conclusions will be discussed further on.

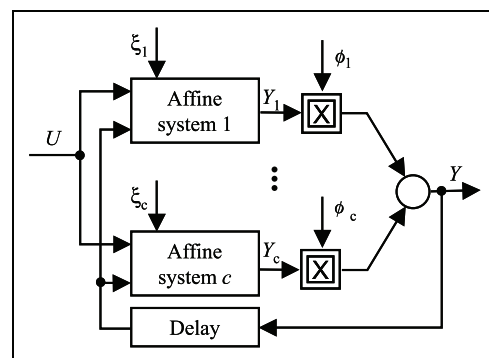

Figure 1: Composition of an TSK model of *c* local models.

4 Deriving State-Space Representations From Affine Local I/O Models

Two alternative transformations of a fuzzy model, which is composed of a set of affine I/O local models, into a fuzzy state-space model will be proposed in the sequel. The first approach is to treat the constants ξ_i as offsets on the input signal. (Treating ξ_i as an offset on the output signal provides for corresponding results in the regular case and is omitted due to restricted space.) The second approach is to treat the constants ξ_i as independent (constant) additional input signals. Only state space models in/similar to the controller canonical form (CF) will be considered. CFs are minimal realizations of state-space models. ‘‘Minimality’’ and structure related properties make them interesting, see [1; 11; 16; 18; 33–35] for further discussion on SISO/MIMO CFs. The controller CF is particularly interesting for controller design. Also, a system representation in CF permits to better exploit recent progress in numerical routines for solving convex optimization problems in terms of LMIs [5; 20; 38; 49]. The choice of the parameters and initial values of state space models in controller CF, which yield equivalent behavior, will be discussed in the following two subsections.

4.1 Interpretation and implications of the local constant terms

In case a global model is available (e. g. from modeling by first principles), a TSK fuzzy model can be derived by linearization around c operating points $(U_{0,i}, Y_{0,i})$ (Fig. 2c). This provides for c linear local models (Fig. 2b). Classifiers μ_i have to be determined, which define the validity of each local model. The offsets on inputs and outputs, which permit a representation in small-signal/local (linear) coordinates (u, y) , are known for all local models (Fig. 2b,c):

$$\begin{aligned}
 Y(k) - Y_0 + \sum_{j=1}^n a_j (Y(k-j) - Y_0) \\
 = \sum_{l=1}^m b_l (U_1(k-l) - U_0) \\
 y(k) + \sum_{j=1}^n a_j y(k-j) = \sum_{l=1}^m b_l u(k-l).
 \end{aligned}
 \tag{3}$$

Equation (3) assumes no direct transmission. Otherwise, the second summation would start from $l = 0$ instead of $l = 1$. For the sake of readability, the index for the local model is omitted until further notice is given.

Determining a TSK fuzzy model by identification provides for only one lumped offset ξ per local model, see Fig. 2a.

As the local model structure is often chosen to be of ARX-type, the following representation $\Sigma_{I/O}$ results (SISO case):

$$\Sigma_{I/O} : Y(k) + \sum_{j=1}^n a_j Y(k-j) = \sum_{l=1}^m b_l U_1(k-l) + \xi
 \tag{4}$$

However, with

$$\xi = Y_0 \left(1 + \sum_{j=1}^n a_j \right) - U_0 \sum_{l=1}^m b_l$$

this is equivalent to the representation derived by linearization. This means, the affine system can be associated with a linear system, where the shifts of input/output quantities are not known individually but only by cumulated effect. This leads to the question, how the lumped offset terms ξ should be treated. Knowing only one lumped constant per local model, no value is seen in having an (arbitrary) individual offset on both, input and output. ξ can be treated as bias on the input, as bias on the output signal, or as independent second input signal of a linear model (Fig. 2d–f). In case of local state-space models ξ could also impact a middle element of the state vector. This will not be considered further due to the focus on CFs.

Approach d) or e) in Fig. 2 differ in case that the nominator or the denominator of the z -transfer function, which is associated with (4), has zero gain. A *zero nominator gain plant* does not permit equilibrium other than with zero output. Positioning ξ as an offset on the plant input would hence not allow adjusting the steady-state output as required. The z -transform of (4) is:

$$\begin{aligned}
 Y(z) = \frac{b_1 z^{-1} + \dots + b_m z^{-m}}{1 + a_1 z^{-1} + \dots + a_n z^{-n}} U(z) \\
 + \frac{1}{1 + a_1 z^{-1} + \dots + a_n z^{-n}} \xi(z).
 \end{aligned}$$

Modeling ξ as bias on the input means:

$$Y(z) = \frac{b_1 z^{-1} + \dots + b_m z^{-m}}{1 + a_1 z^{-1} + \dots + a_n z^{-n}} \left(U(z) + \left(\sum_{l=1}^m b_l \right)^{-1} \xi \right)$$

A zero gain of the nominator of the transfer function ($\sum_{l=1}^m b_l = 0$) causes a singularity. This is consistent with the qualitative explanation above. In such a case, ξ should be modeled as bias on the output:

$$Y(z) = \frac{b_1 z^{-1} + \dots + b_m z^{-m}}{1 + a_1 z^{-1} + \dots + a_n z^{-n}} U(z) + \left(1 + \sum_{j=1}^n a_j \right)^{-1} \xi.$$

A *zero denominator gain* means an integrating or a not-dampened oscillating plant. An integrating plant has only

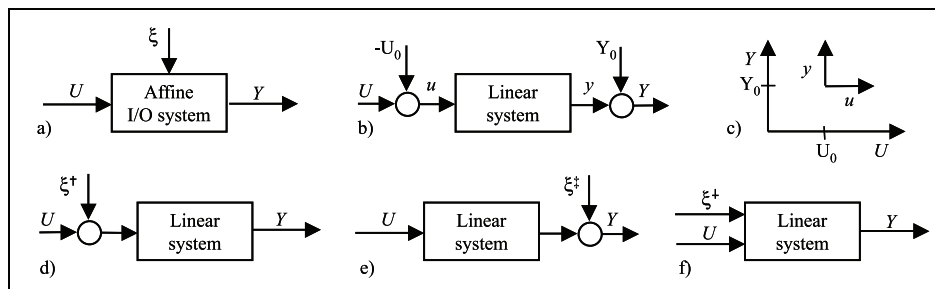

Figure 2: Local dynamic model resulting from modeling by a) TSK identification or b+c) linearization of a global nonlinear model. Modeling the constant term as d) input offset, e) output offset and f) additional constant input of a linear system.

a constant equilibrium in case the input is zero. A not-dampened oscillating plant has only a constant equilibrium in case it is not excited by initial values or an external input. For such a plant the offset ξ should be considered as bias on the input. In the case that neither nominator nor denominator gain are zero, modeling ξ as offset on input or output provides for equivalent results.

4.2 State-space system with offset on input signal

An affine local SISO model as of equation (4) can be rewritten as a linear state-space model with an offset on its input signal (Fig. 2d). As the objective is to obtain a structure, which is close to the controller CF, offset and input are kept as separate additive vectors. Then the following theorem can be derived:

Theorem 1. SISO state space model in controller CF with offset on input

A SISO I/O type (affine) local dynamic model representation as of equation (4) with the initial values $Y_0, \dots, Y_n, U_{1,n-m} \dots, U_{1,n-1}$ and with $\sum_{l=1}^m b_l \neq 0$ and $1 \leq m \leq n$ is equivalent to the minimal representation Σ_{ACF} :

$$\sum_{ACF} : \begin{cases} \mathbf{X}(k+1) = \mathbf{A}\mathbf{X}(k) + \mathbf{b}U_1(k) + \mathbf{q}\xi, \mathbf{X}_0 = \mathbf{X}(k_0) \\ Y(k+1) = \mathbf{c}\mathbf{X}(k+1) \end{cases} \quad (5)$$

with the state vector:

$$\mathbf{X}(k) = [H(k-n+1) \dots H(k-1)H(k)]^T \quad (6)$$

and the system matrices and vectors:

$$\mathbf{A} = \begin{bmatrix} 0 & 1 & & (0) \\ \vdots & \ddots & \ddots & \\ 0 & \dots & 0 & 1 \\ -a_n & \dots & \dots & -a_1 \end{bmatrix}; \mathbf{b} = \begin{bmatrix} 0 \\ \vdots \\ 0 \\ 1 \end{bmatrix};$$

$$\mathbf{q} = \begin{bmatrix} 0 \\ \vdots \\ 0 \\ (\sum_{l=1}^m b_l)^{-1} \end{bmatrix}; \mathbf{c} = \begin{bmatrix} 0 \\ b_m \\ \vdots \\ b_1 \end{bmatrix}^T \quad (7)$$

The initial values H_0, \dots, H_{n-1} of Σ_{ACF} can uniquely be derived from the initial values of $\Sigma_{I/O}$. In case

$1 + \sum_{i=1}^n a_i \neq 0$ and in case the system is initially in equilibrium,

$$H_0 = \left(\frac{\xi}{\sum_{l=1}^m b_l} + U_{1,0} \right) \left(1 + \sum_{i=1}^n a_i \right)^{-1} \quad (8)$$

holds for all elements of the initial state-vector \mathbf{X}_0 . In case the (non-integrating) system is initially not in equilibrium, the components of \mathbf{X}_0 can be calculated by solving a set of linear equations (see proof).

Proof. The proof is given in appendix A.

Figure 3 shows the block scheme for Σ_{ACF} . The linear controller CF follows directly for $\xi = 0$. Note:

- i) The physical interpretability of the state (given in case the state vector is assembled of delayed I/O quantities) is lost after the transformation into Σ_{ACF} . This is inherent to CFs.
- ii) An alternative representation, where the state is augmented by delayed inputs is described in [22]. While having the same number of parameters $n + m$, it does not fulfill the requirement of CFs' to have a minimal number of delay elements.
- iii) $Y(k+1)$ is used instead of $Y(k)$ as this is more suitable in practical applications of state-space models, where the output equation is evaluated after the state equation [11].

The global state-space model follows by superposing c affine local dynamic SISO models Σ_{ACF} :

$$\begin{aligned} \mathbf{X}(k+1) &= \sum_{i=1}^c \phi_i(k) \mathbf{X}_i(k+1) \\ &= \left[\sum_{i=1}^c \phi_i(k) \mathbf{A}_i \mathbf{X}_i(k) \right] + \left[\sum_{i=1}^c \phi_i(k) \right] \mathbf{e} U_1(k) \\ &\quad + \sum_{i=1}^c \phi_i(k) \mathbf{q}_i \xi_i \\ Y(k+1) &= \sum_{i=1}^c \phi_i(k) Y_i(k+1) \\ &= \sum_{i=1}^c \phi_i(k) \mathbf{c}_i \mathbf{X}_i(k+1) \end{aligned} \quad (9)$$

with the unit vector $\mathbf{e} = [(0) \ 1]^T$. The global fuzzy state-space model is of explicitly affine form. As the local offsets vary in general, there is no constant global offset. Hence,

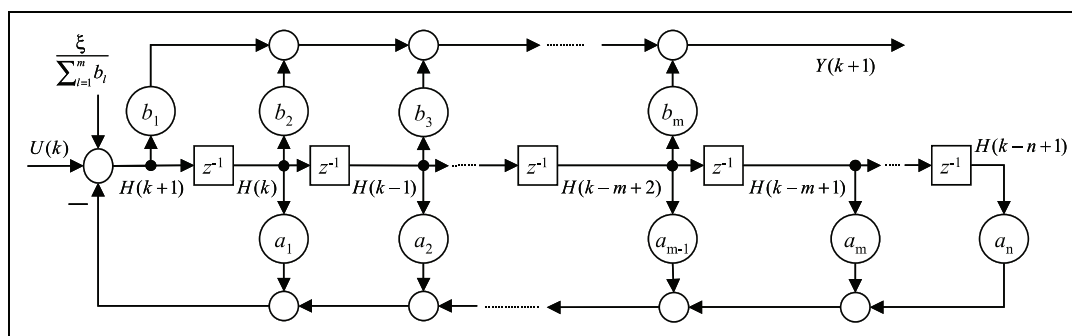

Figure 3: Affine system representation as SISO controller CF, constant considered as offset on input (no direct transmission).

the global model cannot be transferred to a linear time varying (LTV) model. The system equation can be written as an affine time-varying SISO model. In case the model is of observer CF, the output equation can be written in LTV form.

4.3 Treating the offset as a second input of a MISO state space model

An affine local model as of equation (4) can be rewritten as a linear local model where the offset is considered as an additional (constant) input (Fig. 2f). The following theorem describes how an affine SISO model can be transformed into a linear MISO model in controller CF. Kailath's scheme II MIMO CF [16] will be used. However, the order of states will be reverted as proposed by Isermann [11] and Schwarz [34] for the SISO case.

Theorem 2. MISO state space model in controller CF with offset treated as second input

An affine SISO I/O model representation as of equation (4) can be rewritten as a (linear) MISO I/O model by representing the offset term as an additional input $U_2 \equiv \xi$. This model with initial values $Y_0, \dots, Y_n, U_{1,n-m} \dots, U_{1,n-1}$ is for $1 \leq m \leq n$ equivalent to the MISO controller CF Σ_{MCF} :

$$\Sigma_{MCF} : \begin{cases} \mathbf{X}(k+1) = \mathbf{A}\mathbf{X}(k) + \mathbf{B}\mathbf{U}(k), \mathbf{X}_0 = \mathbf{X}(k_0) \\ Y(k+1) = \mathbf{c}\mathbf{X}(k+1) + \mathbf{d}\mathbf{U}(k) \end{cases} \quad (10)$$

with the state vector:

$$\mathbf{X}(k) = [H(k-n+1) \ \dots \ H(k-1) \ H(k) \ H^*(k)]^T \quad (11)$$

the input vector:

$$\mathbf{U}(k) = [U_1(k) \ U_2(k)]^T \quad (12)$$

and system matrices and vectors:

$$\mathbf{A} = \left[\begin{array}{cccc|c} 0 & 1 & & (0) & 0 \\ \vdots & \ddots & \ddots & & \vdots \\ 0 & \dots & 0 & 1 & 0 \\ \hline -\alpha_{11,n} & \dots & \dots & -\alpha_{11,1} & \alpha_{12} \\ (0) & & & & 0 \end{array} \right]; \quad (13)$$

$$\mathbf{B} = \begin{bmatrix} 0 & 0 \\ \vdots & \vdots \\ 0 & \vdots \\ 1 & 0 \\ 0 & 1 \end{bmatrix}; \quad \mathbf{c} = \begin{bmatrix} (0) \\ b_m \\ \vdots \\ b_1 \\ \beta \end{bmatrix}^T$$

$$\mathbf{d} = [0 \ d_2], U_2(k) = \xi, \alpha_{11,j} = a_j. \quad (14)$$

The asterisk (H^*) indicates the augmented state-vector element. Σ_{MCF} can be constructed in 3 alternative ways:

$$A1 : \alpha_{12} = 1 / \sum_{l=1}^m b_l, \beta = d_2 = 0 \quad (15)$$

$$A2 : \alpha_{12} = \beta = 0, d_2 = 1 / \left(1 + \sum_{j=1}^n a_j\right) \quad (16)$$

$$A3 : \alpha_{12} = d_2 = 0, \beta = 1 / \left(1 + \sum_{j=1}^n a_j\right). \quad (17)$$

Case A1 assumes a plant with nonzero gain of the nominator of the plant transfer function ($\sum_{l=1}^m b_l \neq 0$). Cases A2 and A3 assume $1 + \sum_{i=1}^n a_i \neq 0$. The initial values of the three alternative representations can be calculated from the ones of $\Sigma_{I/O}$ (see proof): A1 has the same initial values for H_0 as specified in Theorem 1 and $H_0^* = \xi$. Both, A2 and A3, have the same initial values. $H_0^* = \xi$ is the element of the initial state-vector related to 2nd subsystem. In case $1 + \sum_{i=1}^n a_i \neq 0$ and if the system is initially in equilibrium:

$$H_0 = U_{1,0} \left(1 + \sum_{i=1}^n a_i\right)^{-1} \quad (18)$$

holds for all elements of the initial state-vector related to the 1st subsystem. In case the system is initially not in equilibrium, the elements of X_0 can be calculated by solving a set of linear equations.

Proof. The proof is given in appendix B.

Figure 4 shows the block scheme for Σ_{MCF} . The MISO system resulting from case A1 is mathematically similar to the SISO system described in Theorem 1, as the offset is handled on the input side. In case of A2 the offset is represented as a direct transmission. Case A3 means that the offset is treated on the output side of the system. Note that $Y(k+1)$ is used instead of $Y(k)$, as this is more suitable in practical applications of state-space models, where the output equation is evaluated after the state equation [11].

In order to superpose c local models:

$$\begin{aligned} \mathbf{X}_i(k+1) &= \mathbf{A}_i \mathbf{X}_i(k) + \mathbf{B}_i \mathbf{U}(k) \\ Y_i(k+1) &= \mathbf{c}_i \mathbf{X}_i(k+1) + \mathbf{d}_i \mathbf{U}(k) \end{aligned} \quad (19)$$

to form the global model, the control vector is altered to accommodate not only one, but all c offsets ξ_j :

$$\begin{aligned} \mathbf{U}(k) &= [U_1(k) \ U_2(k) \ \dots \ U_{c+1}(k)]^T, \\ U_{l+1}(k) &= \xi_l, l = 1, \dots, c \end{aligned} \quad (20)$$

Additionally, the following definition is used:

$$\mathbf{d}_i = [d_{1,i} \ \delta_{1,i} \ \dots \ \delta_{c,i}], \delta_{j,i} = \begin{cases} d_{2,i} & \text{for } j = i \\ 0 & \text{for } j \neq i \end{cases}, j = 1, \dots, c \quad (21)$$

Then the global state-space model follows as:

$$\begin{aligned} \mathbf{X}(k+1) &= \left[\sum_{i=1}^c \phi_i(k) \mathbf{A}_i \mathbf{X}_i(k) \right] \\ &\quad + \left[\sum_{i=1}^c \phi_i(k) \mathbf{B}_i \right] \mathbf{U}(k) \\ Y(k+1) &= \left[\sum_{i=1}^c \phi_i(k) \mathbf{c}_i \mathbf{X}_i(k+1) \right] \\ &\quad + \left[\sum_{i=1}^c \phi_i(k) \mathbf{d}_i \right] \mathbf{U}(k) \end{aligned} \quad (22)$$

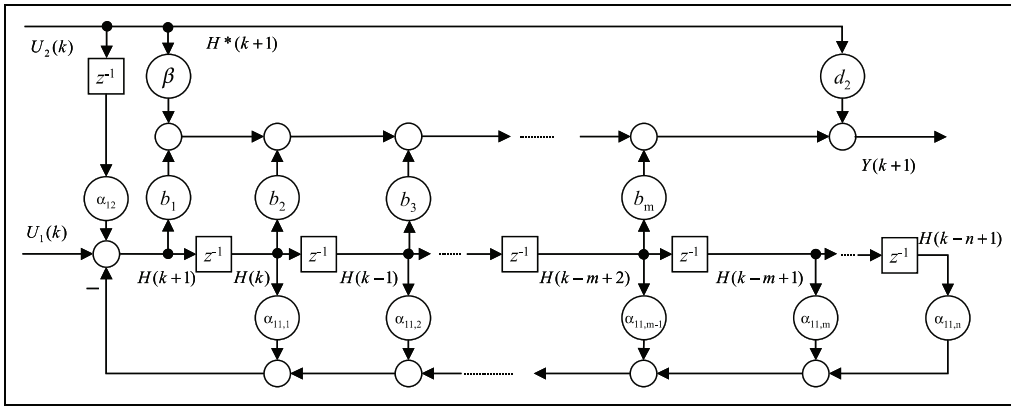

Figure 4: Affine system representation as MISO controller CF ($U_2 = \xi$).

Assuming a common state $\mathbf{X}(k)$ of all local models, the following is obtained:

$$\begin{aligned} \mathbf{X}(k+1) &= \left[\sum_{i=1}^c \phi_i(k) \mathbf{A}_i \right] \mathbf{X}(k) \\ &+ \left[\sum_{i=1}^c \phi_i(k) \mathbf{B}_i \right] \mathbf{U}(k) \\ Y(k+1) &= \left[\sum_{i=1}^c \phi_i(k) \mathbf{c}_i \mathbf{X}_i(k+1) \right] \\ &+ \left[\sum_{i=1}^c \phi_i(k) \mathbf{d}_i \right] \mathbf{U}(k) \end{aligned} \quad (23)$$

As mentioned before, A1 and A2 yield a system without direct transmission. As in the SISO case, equation (23) can also be written as a LTV MISO model.

5 Example

The proposed concepts are illustrated with a simple, but frequently used example: the TSK fuzzy model in [40–43; 47] with two local models. However, the originally used linear local state space models are extended by arbitrarily chosen offset terms to gain affine local models.

5.1 Local models of the original system

The first local state-space model is given by:

$$\sum_{I/O1} : Y(k) = Y(k-1) - 0.5Y(k-2) + 0.2U_1(k-1) + 0.5$$

This means $a_1 = -1$, $a_2 = 0.5$, $b_1 = 0.2$, $b_2 = 0$, and $\xi = 0.5$.

In the first scenario, the system is initially in equilibrium with $U_1(0) = U_1(1) = 0$. Equation (32) provides for $Y(0) = 1$. In the second scenario, the system is initially not in equilibrium. To have a setting similar to the equilibrium case, $U_1(0) = 0$, $U_1(1) = 0$, $Y(0) = 0.5$, $Y(1) = 1$ are used. This provides for $Y(2) = 1.25$.

The second local state-space model is given by:

$$\sum_{I/O2} : Y(k) = -Y(k-1) - 0.5Y(k-2) + 0.4U_1(k-1) - 0.5$$

This means $a_1 = 1$, $a_2 = 0.5$, $b_1 = 0.4$, $b_2 = 0$, and $\xi = -0.5$.

5.2 State space model with offset on input

Using Theorem 1, Σ_{ACF1} (first model) can be directly written as:

$$\begin{aligned} \begin{bmatrix} H(k) \\ H(k+1) \end{bmatrix} &= \begin{bmatrix} 0 & 1 \\ -0.5 & 1 \end{bmatrix} \begin{bmatrix} H(k-1) \\ H(k) \end{bmatrix} + \begin{bmatrix} 0 \\ 1 \end{bmatrix} U_1(k) + \begin{bmatrix} 0 \\ 2.5 \end{bmatrix} \\ Y(k+1) &= [0 \ 0.2] [H(k) \ H(k+1)]^T \end{aligned}$$

This is, Σ_{ACF1} is given as:

$$\sum_{ACF1} : \begin{aligned} \mathbf{X}_1(k+1) &= \mathbf{A}_1 \mathbf{X}_1(k) + \mathbf{b}_1 U_1(k) + \mathbf{q}_1 \xi, \\ \mathbf{X}_{1,0} &= \mathbf{X}_1(k_0) \\ Y_1(k+1) &= \mathbf{c}_1 \mathbf{X}_1(k+1) \end{aligned}$$

with

$$\begin{aligned} \mathbf{A}_1 &= \begin{bmatrix} 0 & 1 \\ -0.5 & 1 \end{bmatrix}; \mathbf{b}_1 = \begin{bmatrix} 0 \\ 1 \end{bmatrix}; \mathbf{q}_1 = \begin{bmatrix} 0 \\ 5 \end{bmatrix}; \\ \xi_1 &= 0.5; \mathbf{c}_1 = \begin{bmatrix} 0 \\ 0.2 \end{bmatrix}^T \end{aligned}$$

For the initial equilibrium scenario, applying (8) provides for $H_0 = 5$ as components of the initial state vector.

In case the system is initially not in equilibrium, equation (34) and equations (35) are used to calculate the unknown $H(0)$, $H(1)$, and $H(2)$. Straightforward calculations provide for analytic expressions for this case ($n = 2$, $m = 2$):

$$\begin{aligned} H(0) &= \frac{1}{\sigma} \left[(b_2 - a_1 b_1) Y(1) - b_1 Y(2) + b_1^2 U_1(1) \right. \\ &\quad \left. + \frac{b_1^2}{b_1 + b_2} \xi \right] \\ H(1) &= \frac{1}{\sigma} \left[a_2 b_1 Y(1) + b_2 Y(2) - b_1 b_2 U_1(1) + \frac{b_1 b_2}{b_1 + b_2} \xi \right] \\ H(2) &= \frac{1}{\sigma} \left[-a_2 b_2 Y(1) + (a_2 b_1 - a_1 b_2) Y(2) + b_2^2 U_1(1) \right. \\ &\quad \left. + \frac{b_2^2}{b_1 + b_2} \xi \right] \end{aligned}$$

with $\sigma = b_2^2 + a_2 b_1^2 - a_1 b_1 b_2$.

The numerical values are: $H(0) = -2.5$, $H(1) = 5$, and $H(2) = 6.25$ for the given case.

Using Theorem 1, Σ_{ACF2} (second model) follows as:

$$\sum_{ACF2} : \begin{aligned} \mathbf{X}_2(k+1) &= \mathbf{A}_2 \mathbf{X}_2(k) + \mathbf{b}_2 U_1(k) + \mathbf{q}_2 \xi_2, \\ \mathbf{X}_{2,0} &= \mathbf{X}_2(k_0) \\ Y_2(k+1) &= \mathbf{c}_2 \mathbf{X}_2(k+1) \end{aligned}$$

with

$$\mathbf{A}_2 = \begin{bmatrix} 0 & 1 \\ -0.5 & -1 \end{bmatrix}; \mathbf{b}_2 = \begin{bmatrix} 0 \\ 1 \end{bmatrix}; \\ \mathbf{q}_2 = \begin{bmatrix} 0 \\ 2.5 \end{bmatrix}; \xi_2 = -0.5; \mathbf{c}_2 = \begin{bmatrix} 0 \\ 0.4 \end{bmatrix}^T$$

Equation (8) provides for $H_0 = -0.5$ for Σ_{ACF2} as components of the initial state vector for the equilibrium scenario. The case that the system is initially not in equilibrium follows as for the first model. The global state-space model is composed as defined in (9).

5.3 State-space model with offset as second input

Alternative A_2 is considered as an example. Using Theorem 2, Σ_{MCF1} (first model) can be written as:

$$\begin{bmatrix} H(k) \\ H(k+1) \\ H^*(k+1) \end{bmatrix} = \begin{bmatrix} 0 & 1 & 0 \\ -0.5 & 1 & 0 \\ 0 & 0 & 0 \end{bmatrix} \begin{bmatrix} H(k-1) \\ H(k) \\ H^*(k) \end{bmatrix} \begin{bmatrix} 0 & 0 \\ 1 & 0 \\ 0 & 1 \end{bmatrix} \begin{bmatrix} U_1(k) \\ U_2(k) \end{bmatrix} \\ Y(k+1) = \begin{bmatrix} 0 \\ 0.2 \\ 0 \end{bmatrix}^T \begin{bmatrix} H(k) \\ H(k+1) \\ H^*(k+1) \end{bmatrix} + [0 \ 2] \begin{bmatrix} U_1(k) \\ U_2(k) \end{bmatrix}$$

Equation (18) provides for $H_0 = 0$ and $H_0^* = 0.5$ for the initial equilibrium scenario. In case the system is initially not in equilibrium, equation (46) and equations (47) are used to calculate the unknown $H(0)$, $H(1)$, and $H(2)$. Straightforward, but lengthy calculations provide for an analytical expression ($n = 2$, $m = 2$):

$$H(0) = \frac{1}{\sigma} \left[(b_2 - a_1 b_1) Y(1) - b_1 Y(2) + b_1^2 U_1(1) \right. \\ \left. + \frac{b_1 - b_2 + a_1 b_1}{1 + a_1 + a_2} \xi \right] \\ H(1) = \frac{1}{\sigma} \left[a_2 b_1 Y(1) + b_2 Y(2) - b_1 b_2 U_1(1) - \frac{b_2 + a_2 b_1}{1 + a_1 + a_2} \xi \right] \\ H(2) = \frac{1}{\sigma} \left[-a_2 b_2 Y(1) + (a_2 b_1 - a_1 b_2) Y(2) + b_2^2 U_1(1) + \eta \xi \right]$$

$$\text{with } \eta = \frac{a_1 b_2 - a_2 b_1 + a_2 b_2}{1 + a_1 + a_2}$$

and with σ as in case of Σ_{ACF1} . The numerical values follow as: $H(0) = -2.5$, $H(1) = 0$, $H(2) = 1.25$, and $H^*(0) = 0.5$.

The second model follows similarly. The global state-space model is composed as defined in equations (19)–(23).

6 Discussion

The presented methods contribute to closing the gap between TSK identification and TSK control-focused papers.

The identification-focused papers typically propose affine I/O models. Contributions on TSK state-space controllers typically neglect the constant term. The most similar works to this paper are [7; 17]. In [7] TSK state-feedback controller and state observer design is discussed. Local state-space models in observable CF are used and the constant term is positioned in the output equation. Local pole placement is used for controller design. [7] assumes having the state-space model to be available, so does paper [17]. The offset is considered in the system equation and no minimal representation is considered in [17]. Controller design is done numerically via LMI tools. None of both papers addresses the issue of gaining state space models from the commonly available local affine I/O ARX-type models. In contrast, this work proposed transformations of local affine I/O ARX-type models into local linear state space models in controller CF. The constant term is handled as additional input signal or as offset on the input signal. Analytical methods for determining initial values, which provide for identical predictions of models in I/O and state-space notation were proposed. In the presented representation, the constant term has no impact on shaping the local dynamic characteristics for state-feedback controller design, which follows e. g. the “parallel distributed compensator” concept, e. g. [47]. The offset terms have to be considered when designing the steady-state signals. This can be done in different ways, see e. g. [22] for more details. This permits a fully rigorous treatment of model identification, control design, and closed-loop simulation studies (and later realization).

The treatment of the constants as additional input signal or as input signal offset have been shown to provide both for equivalent representations. In practice, the author would use the SISO approach being more compact and straightforward.

Using minimal realizations has pros and cons as compared with non-minimal realization and is finally a matter of personal preference: A disadvantage is the lack of physical interpretability of the state. On the contrary, minimal and structural properties are advantageous. For example, non-minimal realizations introduce artificial additional poles, which need to be considered in controller/observer design.

Using the same (global) *current* state for each local system is preferable over independent current local states and also the standard in literature (but seldom explicitly stated). This is achieved by *state-reconstruction*. Then the state of the local models is reinitialized identically for all local models in each time step [22]. Finding different local initial states for each regime is more difficult and also makes system analysis more difficult. It is mentioned that the TSK fuzzy systems provide per definition for a *numerical* interpolation during transitions between the local systems. This contribution has not discussed aspects of transition between local systems. Treating an affine system as a LTV system provides for little advantage: As each parameter of the system description is time-varying and depends on the present

membership, a practical application of standard methods such as those in [26] is not possible.

7 Conclusions

Affine local I/O models of TSK fuzzy systems, which commonly originate from TSK fuzzy identification, can be transformed into local linear state-space models with the constant terms being correctly treated as offset on input or on output signal or as an additional input signal of the model. This approach permits a *formally correct* local application of linear analytic methods for e. g. state-feedback controller design. The provided analytical formulas to determine model parameters and initial values make the model transformation quick and easy.

These methods reduce the gap between works on TSK fuzzy control and identification: TSK control papers do commonly not consider model derivation. Works on TSK identification seldom address fuzzy state-space models.

Little discussed were the consequences of the fuzzy composition of the local systems to form a global system: Control design methods often focus on designing the local dynamics. The transitions result typically from *numerical* interpolation between the local *signals*. Consideration of system properties during transitions and shaping transitions with analytical methods can be an interesting field for further research.

Appendices

A Proof of Theorem 1

Proof [Theorem 1]: The proof consists of two parts: Part 1 derives the structure and parameters of Σ_{ACF} from $\Sigma_{I/O}$; Part 2 treats the initial value transformation from $\Sigma_{I/O}$ to Σ_{ACF} .

Part 1: It is to be shown that $\Sigma_{I/O}$ according to equation (4) is equivalent to Σ_{ACF} according to equations (5)–(7). Σ_{ACF} can be written as:

$$H(k+1) = U_1(k) + \xi / \sum_{l=1}^m b_l - \sum_{i=1}^n a_i H(k-i+1) \tag{24}$$

$$Y(k+1) = \sum_{j=1}^m b_j H(k-j+2) \tag{25}$$

Applying the z -Transformation yields:

$$H(z)z = U_1(z) + Z(\xi) / \sum_{l=1}^m b_l - \sum_{i=1}^n a_i H(z)z^{-i+1} \tag{26}$$

$$Y(z)z = \sum_{j=1}^m b_j H(z)z^{-j+2} \tag{27}$$

where $Z(\xi)$ denotes the z -Transform of ξ . Multiplication with z^{-1} and rewriting of equation (26) provides for:

$$H(z) \left(1 + \sum_{i=1}^n a_i z^{-i} \right) = U_1(z)z^{-1} + \frac{z^{-1}}{\sum_{l=1}^m b_l} Z(\xi) \tag{28}$$

Multiplication of equation (27) with $z^{-1} \left(1 + \sum_{i=1}^n a_i z^{-i} \right)$ permits to substitute its term $H(z) \left(1 + \sum_{i=1}^n a_i z^{-i} \right)$ with the right side of equation (28). This results in:

$$Y(z) \left(1 + \sum_{i=1}^n a_i z^{-i} \right) = \sum_{j=1}^m b_j U_1(z)z^{-j} + \sum_{j=1}^m b_j \frac{Z(\xi)z^{-j}}{\sum_{l=1}^m b_l} \tag{29}$$

Before carrying out the back-transformation into the time domain, assume that ξ is modeled as a step change from 0 to ξ_0 at time $-\tau$: $\xi(k) = \xi_0 1(k+\tau)$ with $\tau \geq m$. This means that the second summation on the right side of (29) is constant for $k \geq 0$. With this assumption the back-transformation yields:

$$Y(k) + \sum_{i=1}^n a_i Y(k-i) = \sum_{j=1}^m b_j U_1(k-j) + \xi \tag{30}$$

which is the I/O representation $\Sigma_{I/O}$ according to equation (4).

Part 2: It is believed that considering an initial state at $k=0$ instead of $k=n-1$ makes it easier to follow the proof. For this reason the initial values $Y_0, \dots, Y_n, U_{1,n-m}, \dots, U_{1,n-1}$ are replaced by $Y_{-n}, \dots, Y_0, U_{1,-m}, \dots, U_{1,-1}$ and the values H_0, \dots, H_n are replaced by H_{-n}, \dots, H_0 .

Let's assume first the system is in equilibrium at $k=0$ for a given input $U_{1,0}$. $\Sigma_{I/O}$ is characterized by the input $U_{1,0}$ and the resulting output Y_0, Σ_{ACF} by the input $U_{1,0}$ and the resulting state \mathbf{X}_0 . Each element of the state-vector \mathbf{X}_0 has the same value H_0 . This is obvious from the block scheme (Fig. 3): All elements of the delay chain have to have the same value for equilibrium. Equations (5)–(7) provide for:

$$H_0 = \left(\frac{\xi}{\sum_{l=1}^m b_l} + U_{1,0} \right) \frac{1}{\left(1 + \sum_{i=1}^n a_i \right)} \tag{31}$$

Inserting H_0 in the output equation (5) yields the same relation between $U_{1,0}$ and Y_0 as $\Sigma_{I/O}$, i. e. both representations have the same equilibrium for given input $U_{1,0}$:

$$\begin{aligned} Y_0 &= H_0 \left(\sum_{l=1}^m b_l \right) \\ &= \left(\xi + U_{1,0} \left(\sum_{l=1}^m b_l \right) \right) \left(1 + \sum_{i=1}^n a_i \right)^{-1} \end{aligned} \tag{32}$$

Let's assume now the system is not in equilibrium at $k=0$. Then the initial values of Σ_{ACF} can be calculated from the initial conditions of the equivalent representation $\Sigma_{I/O}$ by solving a linear set of equations. The set of equations is derived as following: At time $k=0$, $\Sigma_{I/O}$ relates $Y_0, Y_{-1}, Y_{-2}, \dots, Y_{-n}, U_{1,-1}, U_{1,-2}, \dots, U_{1,-m}$ with each other:

$$\sum_{I/O} Y(0) + \sum_{j=1}^n a_j Y(0-j) = \xi + \sum_{l=1}^m b_l U_1(0-l) \tag{33}$$

The n components $H_0, H_{-1}, H_{-2}, \dots, H_{1-n}$ of the initial state-vector \mathbf{X}_0 have to be determined. Σ_{ACF} provides for the two equations (24) and (25). To relate $\Sigma_{I/O}$ and Σ_{ACF} , Σ_{ACF} has to be considered at $k=-1$ such that the

most recent quantity in Σ_{ACF} relates to time 0 (avoiding an unwanted additional unknown $H(1)$)

$$H_0 = U_{1,-1} + \xi \left/ \sum_{l=1}^m b_l - \sum_{i=1}^n a_i H_{-i} \right. \quad (34)$$

The number of unknowns is $n+1$: $H_0, H_{-1}, H_{-2}, \dots, H_{-n}$. The output equation (25) is considered at times $k = -1$ to $k = -n$ to provide for n further equations:

$$\begin{aligned} Y_0 &= \sum_{j=1}^m b_j H_{1-j} \\ &\vdots \\ Y_{1-n} &= \sum_{j=1}^m b_j H_{2-n-j} \end{aligned} \quad (35)$$

In case $m \leq 2$ the $n+1$ unknowns can be derived from these $n+1$ equations. However, in case $m > 2$ the consideration of the output equation in past times introduces $m-2$ further unknowns $H_{-1-n}, \dots, H_{2-m-n}$. The missing $m-2$ additional equations can be obtained by considering the system equations not only at time 0 but also at times $-1, \dots, 2-m$. This yields the additionally required $m-2$ equations:

$$\begin{aligned} H_{-1} &= U_{1,-2} + \xi \left/ \sum_{l=1}^m b_l - \sum_{i=1}^n a_i H_{-1-i} \right. \\ &\vdots \\ H_{2-m} &= U_{1,1-m} + \xi \left/ \sum_{l=1}^m b_l - \sum_{i=1}^n a_i H_{2-m-i} \right. \end{aligned} \quad (36)$$

These $n+1$ equations in case of $m \leq 2$ (and $n+m-1$ for $m > 2$) permit to calculate the $n+1$ unknowns (and $n+m-1$ in case of $m > 2$) including the n components $H_0, H_{-1}, H_{-2}, \dots, H_{1-n}$ of the initial state-vector \mathbf{X}_0 . Q.e.d.

B Proof of Theorem 2

Proof [Theorem 2]

Alternative A1: In this alternative $U_2(k) = \xi$ is weighted with $\alpha_{12} = (\sum_{l=1}^m b_l)^{-1}$ before being added to $U_1(k)$ at the beginning of the delay chain (see Fig. 4). This is mathematically the same as the previous derivation of Σ_{ACF} from $\Sigma_{I/O}$ differing only by an additional delay element between ξ and $Y(k+1)$. Though this delay plays no role as ξ is constant. (Only in the assumption that ξ is modeled as a step change from 0 to ξ_0 at time $-\tau$, $\tau > m$ has to be chosen.) Therefore the reader is referred to the proof of Theorem 1.

Alternative A2: In this alternative it is to be shown that $\Sigma_{I/O}$ according to (4) is equivalent to Σ_{MCF} according to equations (10)–(14) with parameterization A2 as of (16). The proof consists of two parts: Part 1 derives the structure and parameters of Σ_{MCF} from $\Sigma_{I/O}$. Part 2 deals with the initial value transformation from $\Sigma_{I/O}$ to Σ_{MCF} . The proof has the same concept and structure than the one for Theorem 1.

Part 1: Σ_{MCF} as of equations (10)–(14) can be written as:

$$H(k+1) = U_1(k) - \sum_{i=1}^n a_i H(k-i+1) \quad (37)$$

$$\begin{aligned} Y(k+1) &= \left(1 + \sum_{j=1}^n a_j\right)^{-1} U_2(k) \\ &\quad + \sum_{j=1}^m b_j H(k-j+2) \end{aligned} \quad (38)$$

Applying the z -Transformation yields:

$$H(z)z = U_1(z) - \sum_{i=1}^n a_i H(z)z^{-i+1} \quad (39)$$

$$Y(z)z = \left(1 + \sum_{j=1}^n a_j\right)^{-1} U_2(z) + \sum_{j=1}^m b_j H(z)z^{-j+2} \quad (40)$$

Multiplication with z^{-1} and rewriting equation (39) provides for:

$$H(z) \left(1 + \sum_{i=1}^n a_i z^{-i}\right) = U_1(z)z^{-1} \quad (41)$$

Multiplication of (40) with $z^{-1}(1 + \sum_{i=1}^n a_i z^{-i})$ permits to substitute its $H(z)(1 + \sum_{i=1}^n a_i z^{-i})$ term with the right side of (41). This results in:

$$\begin{aligned} Y(z) \left(1 + \sum_{i=1}^n a_i z^{-i}\right) &= \\ &= \left(1 + \sum_{j=1}^n a_j\right)^{-1} U_2(z)z^{-1} \left(1 + \sum_{i=1}^n a_i z^{-i}\right) \\ &\quad + \sum_{j=1}^m b_j U_1(z)z^{-j} \end{aligned} \quad (42)$$

Before carrying out the back transformation into the time domain, assume that ξ is modeled as a step change from 0 to ξ_0 at time $-\tau$: $\xi(k) = \xi_0 1(k+\tau)$ with $\tau \geq n+1$. This means that the $U_2(z)$ related term in (42) is constant for $k \geq 0$. With this assumption back-transformation yields

$$Y(k) + \sum_{i=1}^n a_i Y(k-i) = \xi + \sum_{j=1}^m b_j U_1(k-j) \quad (43)$$

which is the I/O representation $\Sigma_{I/O}$ according to equation (4).

Part 2: It is believed that considering an initial state at $k=0$ instead of $k=n-1$ makes it easier to follow the proof. For this reason the initial values $Y_0, \dots, Y_n, U_{1,n-m}, \dots, U_{1,n-1}$ are replaced by $Y_{-n}, \dots, Y_0, U_{1,-m}, \dots, U_{1,-1}$ and the values H_0, \dots, H_n are replaced by H_{-n}, \dots, H_0 .

Let's assume first the system is in equilibrium at $k=0$ for a given input $U_{1,0}$. $\Sigma_{I/O}$ is characterized by the input $U_{1,0}$ and the resulting output Y_0 , Σ_{MCF} by the input $U_{1,0}$ and the resulting state-vector elements H_0 of subsystem 1 and H_0^* of subsystem 2. Each element of the state-vector \mathbf{X}_0 , which relates to subsystem 1, has the same value H_0 . This is obvious from the block scheme (Fig. 4): All elements of the delay chain have to have the same value for equilibrium. Equations (10)–(14) provide for:

$$H_0 = \frac{U_{1,0}}{\left(1 + \sum_{i=1}^n a_i\right)}, H_0^* = U_{2,0} = \xi \quad (44)$$

Inserting H_0 and H_0^* in the output equation (10) yields the same relation between $U_{1,0}$, $U_{2,0}$, and Y_0 as $\Sigma_{I/O}$, i. e. both

representations have the same equilibrium for given inputs $U_{1,0}$ and $U_{2,0} = \xi$:

$$\begin{aligned}
 Y_0 &= U_{10} \frac{\left(\sum_{l=1}^m b_l\right)}{\left(1 + \sum_{i=1}^n a_i\right)} + \frac{\xi}{\left(1 + \sum_{i=1}^n a_i\right)} \\
 &= \frac{\xi + U_{10} \left(\sum_{l=1}^m b_l\right)}{\left(1 + \sum_{i=1}^n a_i\right)} \quad (45)
 \end{aligned}$$

Let's assume now the system is not in equilibrium at $k = 0$. Then the initial values of Σ_{MCF} can be calculated from the initial conditions of the equivalent system $\Sigma_{I/O}$ by solving a linear set of equations. The set of equations is derived as following: At time $k = 0$, $\Sigma_{I/O}$, relates $Y_0, Y_{-1}, Y_{-2}, \dots, Y_{-n}, U_{1,-1}, U_{1,-2}, \dots, U_{1,-m}$ with each other according to equation (33).

To be determined are the n components $H_0, H_{-1}, H_{-2}, \dots, H_{1-n}$ of the subsystem 1 part of the initial state-vector \mathbf{X}_0 . H_0^* of subsystem 2 is already known to be ξ . Σ_{MCF} provides for the two equations (37) and (38) with $U_2(k) = \xi$.

To relate $\Sigma_{I/O}$ and Σ_{MCF} , Σ_{MCF} has to be considered at $k = -1$ such that the most recent quantity in Σ_{MCF} relates to time 0 (i.e. to avoid an unwanted additional unknown $H(1)$):

$$H_0 = U_{1,-1} - \sum_{i=1}^n a_i H_{-i} \quad (46)$$

The number of unknowns is $n + 1$: $H_0, H_{-1}, H_{-2}, \dots, H_{-n}$. The output (38) is considered at times $k = -1$ to $k = -n$ to provide for n further equations:

$$\begin{aligned}
 Y_0 &= \xi \left(1 + \sum_{j=1}^n a_j\right)^{-1} + \sum_{j=1}^m b_j H_{1-j} \\
 &\quad \vdots \\
 Y_{1-n} &= \xi \left(1 + \sum_{j=1}^n a_j\right)^{-1} + \sum_{j=1}^m b_j H_{2-n-j}
 \end{aligned} \quad (47)$$

In case $m \leq 2$ the $n + 1$ unknowns can be calculated out of these $n + 1$ equations. However, in case $m > 2$ the consideration of the output equation in past times introduces $m - 2$ further unknowns $H_{-1-n}, \dots, H_{2-m-n}$. The missing $m - 2$ additional equations can be obtained by considering the system equations not only at time 0 but also at times $-1, \dots, 2 - m$. This yields the additionally required $m - 2$ equations:

$$\begin{aligned}
 H_{-1} &= U_{1,-2} - \sum_{i=1}^n a_i H_{-1-i} \\
 &\quad \vdots \\
 H_{2-m} &= U_{1,1-m} - \sum_{i=1}^n a_i H_{2-m-i}
 \end{aligned} \quad (48)$$

These $n + 1$ equations in case of $m \leq 2$ (and $n + m - 1$ for $m > 2$, respectively) permit to calculate the $n + 1$ unknowns (and $n + m - 1$ in case of $m > 2$, respectively) including the n components $H_0, H_{-1}, H_{-2}, \dots, H_{1-n}$ of the initial state-vector \mathbf{X}_0 . (The additional component H_0^* is already known.). Q.e.d.

Alternative A3: In this case it is to be shown that the I/O representation $\Sigma_{I/O}$ according to equation (4) is equivalent to the representation Σ_{MCF} according to equations (10)–(14) with parameterization A3 corresponding to (17). Σ_{MCF} can be written identically as A2 in form of equations (37) and (38) and therefore it is referred to the proof of A2.

Acknowledgements

The author thanks his colleague Rasmus Nyström for several useful discussions and the anonymous reviewers for their valuable comments, which helped to improve the paper.

References

- [1] Ackermann, J. 1982. *Sampled data Control I*. Berlin: Springer.
- [2] Babuska, R. 1998. *Fuzzy modeling for control*. Norwell: Kluwer.
- [3] Bernd, T., and A. Kroll. 1997. LS-optimal fuzzy modelling and its application to pneumatic drives. *European Control Conference ECC 97, Bruxelles, 1.–4.09.1997*.
- [4] Bergsten, P., and B. Iliev. 2000. LMI based controller design for affine Takagi Sugeno fuzzy systems. *UKACC International Conference on Control, Cambridge, UK, 4–7.09.2000*.
- [5] Boyd, S., L.E. Ghaoui, E. Feron, and V. Balakrishnan. 1994. *Linear matrix inequalities in system and control theory*. Philadelphia: SIAM.
- [6] Cao, S.-G., N.W. Rees, and G. Feng. 1997. Analysis and design for a class of complex control systems part II: fuzzy controller design. *Automatica*, Vol. 33, No. 6. 1029–1039.
- [7] Cao, S.-G., N.W. Rees, and G. Feng. 1999. Analysis and design of fuzzy control systems using dynamic fuzzy-state space models. *IEEE Transactions on Fuzzy Systems*. April 1999, Vol. 7, No. 2. 192–200.
- [8] Domanski, P.D., M.A. Brdys, and P. Tatjewski. 1997. Fuzzy logic multi-regional controllers – design and stability analysis. *European Control Conference ECC 97, Bruxelles, 1.–4.09.1997*.
- [9] Hadjili, M.L., and V. Wertz. 2002. Takagi–Sugeno modeling incorporating input variable selection. *IEEE Transactions on Fuzzy Systems*, December 2002, Vol. 10, No. 6. 728–742.
- [10] Heckenthaler, T., and S. Engell. 1993. Robust almost time-optimal fuzzy control of a two-tank system. *2nd IEEE Conference on Control Applications, Vancouver, 13–16.9.1993*. 197–202.
- [11] Isermann, R. 1987. *Digital Control Systems I*. Berlin: Springer.
- [12] Johansen, T.A., K.J. Hunt, P.J. Gawthrop, and H. Fritz. 1998. Off-equilibrium linearisation and design of gain-scheduled control with application to vehicle speed control. *Control Engineering Practice* Vol. 6. 167–180.
- [13] Johansen, T.A., and R. Murray-Smith. 1998. Operating regime approach to nonlinear modeling and control, in: *Multiple model approaches to modeling and control*. Eds. R. Murray-Smith and T.A. Johanson. Hants, UK: Taylor Francis. 3–72.
- [14] Johansson, M., and A. Rantzer. 1999. Computation of piecewise quadratic lyapunov functions for hybrid systems. *European Control Conference ECC 97, Bruxelles, 1.–4.09.1997*.
- [15] Julian, P.M. 1999. A high level canonical piecewise linear representation: Theory and applications. PhD thesis, Dep. of Electrical Engineering, Universidad Nacional Del Sur, Bahia Blanca, Argentina.

- [16] Kailath, T. 1980. Linear Systems. Englewood Cliffs: Prentice-Hall.
- [17] Kim, E., and D. Kim. 2001. Stability analysis and synthesis for an affine fuzzy system via LMI and ILMI: Discrete case. IEEE Transactions on Systems, Man, and Cybernetics – part B: Cybernetics, Vol. 31, No. 1. 132–140.
- [18] Kuo, C.K. 1992. Digital control systems. New York: Oxford University Press.
- [19] Korba, P. 2000. A gain-scheduling approach to model-based fuzzy control. PhD thesis, Dep. of Electrical Engineering, University of Duisburg, Germany.
- [20] Korba, P., and P.M. Frank. 1997. Controller design for a class of nonlinear systems based on the Takagi–Sugeno model. Proc. of GMA FA Fuzzy Control, Dortmund, Germany: Univ. of Dortmund. 80–92.
- [21] Kortmann, P., and H. Unbehauen. 1996. Identification of the structure of fuzzy models. Proc. Fuzzy 96, Zittau, Germany, 24–27.09.1996. 36–46.
- [22] Kroll, A., T. Bernd, and S. Trott. 2000. Fuzzy Network Model-Based Fuzzy State Controller Design. IEEE Transactions on Fuzzy Systems, October 2000, Vol. 8, No. 5. 632–644.
- [23] Lam, H.K., F.H.F. Leung, and P.K.S. Tam. 2002. A linear matrix inequality approach for the control of uncertain fuzzy systems. IEEE Control Systems Magazine, August 2002. 20–25.
- [24] Leenaerts, D.M.W., and W.M.G. Bokhoven. 1998. Piecewise linear modeling and analysis. Boston: Kluwer Academic Publishers.
- [25] Leith, D.J., and W.E. Leithead. 1999. A novel class of blended multiple model system with linear local models. European Control Conference ECC 99, Karlsruhe, Germany, 31.08.–3.09.1999.
- [26] Ludyk, G. 1981. Time-variant discrete-time systems. Braunschweig, Wiesbaden: Vieweg.
- [27] Ma, X.-J., Z.-Q. Sun, and Y.-Y. He. 1998. Analysis and design of fuzzy controller and fuzzy observer. IEEE Transactions on Fuzzy Systems, February 1998, Vol. 6, No. 1. 41–51.
- [28] Morse, A.S. 1996. Supervisory control of families of linear set-point controllers – part 1: Exact matching. IEEE Transactions on Automatic Control, October 1996, Vol. 41, No. 10. 1413–1431.
- [29] Nelles, O. 2001. Nonlinear system identification. Berlin: Springer.
- [30] Pickhardt, R. 1995. Adaptive control with a multi model method (in German). PhD thesis. University of Bochum. VDI Fortschrittberichte, Series 8, No. 499. Düsseldorf: VDI Verlag.
- [31] Poggio, T., and F. Girosi. 1989. Regularization algorithms for learning that are equivalent to multilayer networks. Science Vol. 24. 978–982.
- [32] Rovatti, R. 1996. Takagi–Sugeno models as approximators in Sobolev norms: the SISO case. 5th IEEE Int. Conference on Fuzzy Systems, New Orleans, 8–11.9.1996. 1060–1066.
- [33] Schwarz, H. 1971. Multivariable control systems I (in German). Berlin: Springer.
- [34] Schwarz, H. 1976. Optimal control of linear systems (in German). Mannheim: BI Wissenschaftsverlag.
- [35] Schwarz, H. 1979. Discrete time control systems (in German). Braunschweig: Vieweg.
- [36] Sugeno, M., and G.T. Kang. 1985. Fuzzy modeling and control of multilayer incinerator. Fuzzy Sets and Systems, No. 18. 329–346.
- [37] Takagi, T., and M. Sugeno. 1983. Derivation of fuzzy control rules from human operator's control actions. Proc. of the IFAC Symposium on Fuzzy Information, knowledge representation and decision analysis, 19–21.07.1983, Marseille, France. 55–60.
- [38] Tanaka, K., T. Ikeda, and H.O. Wang. 1996. Robust Stabilization of a class of uncertain nonlinear systems via fuzzy control: quadratic stabilizability, H_∞ control theory, and linear matrix inequalities. IEEE Transactions on Fuzzy Systems, February 1996, Vol. 4, No. 1. 1–13.
- [39] Tanaka, K., T. Ikeda, and H.O. Wang. 1998. Fuzzy regulators and fuzzy observers: relaxed stability and LMI-based designs. IEEE Transactions on Fuzzy Systems, May 1998, Vol. 6, No. 2. 250–265.
- [40] Tanaka, K., and M. Sano. 1993. Fuzzy stability criterion of a class of nonlinear systems. Information Sciences Vol. 71. 3–26.
- [41] Tanaka, K., and M. Sano. 1994. A robust stabilization problem of fuzzy control systems and its application to backing up control of a truck-trailer. IEEE Transactions on Fuzzy Systems, May 1994, Vol. 2, No. 2. 119–134.
- [42] Tanaka, K., and M. Sugeno. 1990. Stability analysis of fuzzy systems using Lyapunov's direct method. Proc. of North American Fuzzy Information Processing Society NAFIPS '90. 133–136.
- [43] Tanaka, K., and M. Sugeno. 1992. Stability analysis and design of fuzzy control systems. Fuzzy Sets and Systems, Vol. 45, 135–156.
- [44] Tseng, C.-S., B.-S. Chen, and H.-J. Uang. 2001. Fuzzy tracking control design for nonlinear dynamic systems via T-S fuzzy model. IEEE Transactions on Fuzzy Systems, Vol. 9, No. 3, June 2001. 381–392.
- [45] van Laak, O., T. Möllers, and H.-J. Wenz. 1999. Multi regional state space systems – controller design and stability. Acta Mathematica et Informatica Universitatis Ostraviensis Vol. 7, 47–60.
- [46] Wang, H.O., J. Li, D. Niemann, and K. Tanaka. 2000. T-S fuzzy Model with Linear Rule Consequence and PDC Controller: A Universal Framework for Nonlinear Control Systems, 9th IEEE International Conference on Fuzzy Systems, San Antonio, May. 549–554.
- [47] Wang, H., K. Tanaka, and M. Griffin. 1995. Parallel distributed compensation of nonlinear systems by Takagi–Sugeno Fuzzy Model. 4th IEEE Conference on Fuzzy Systems, 1995. 531–538.
- [48] Zak, S.H. 1999. Stabilizing fuzzy system models using linear controllers. IEEE Transactions on Fuzzy Systems, April 1999, Vol. 7, No. 2. 236–240.
- [49] Zhao, J., V. Wertz, and R. Gorez. 1995. Design a stabilizing fuzzy and/or nonfuzzy state-feedback controller using LMI-method. Proc. 3rd European Control Conference, Rome, Vol. 3. 1201–1206.
- [50] Zhao, J., V. Wertz, and R. Gorez. 1996. Dynamic fuzzy state feedback controller and its limitations. Proc. 13th IFAC World Congress, San Francisco, 30.06–5.07.1996. 121–126.

Manuscript received: 15. April 2004.



Dr.-Ing. Andreas Kroll leads the group “Control & Optimization” of ABB’s German Corporate Research Center. The research interests of the group include: methods and systems for advanced process control, real-time optimization, monitoring & diagnosis and planning & scheduling for application in the process industries.

Address: ABB AG – Corporate Research Germany, Dept. I4: Control & Optimization, Wallstadter Str. 59, 68526 Ladenburg, Tel.: +49-(0)-6203-71-6252, Fax: +49-(0)-6203-71-6253, E-Mail: andreas.a.kroll@de.abb.com